



STANDARD EQUIPMENT

ENGINE:

- Automatic engine warm-up system
- Dry type air cleaner, double element
- Engine, Komatsu SAA6D114E-3
- Engine overheat prevention system
- Radiator and oil cooler dust proof net
- Suction fan
- Large capacity fuel pre-filter
- Precleaner

ELECTRICAL SYSTEM:

- Alternator, 24 V/60 A
- Auto-decelerator
- Batteries, 2 X 12 V/126 Ah
- Starting motor, 24 V/7.5 kW
- Working light, 2 (Boom and RH)
- Working light, boom X 1 and right console

HYDRAULIC SYSTEM:

- Boom holding valve
- Power maximizing system
- Pressure Proportional Control (PPC) hydraulic control system
- Two-mode settings for boom
- Working mode selection system

GUARDS AND COVERS:

- Fan guard structure
- Track guiding guard, center section (2 on each side)

UNDERCARRIAGE:

- Hydraulic track adjusters (Each side)
- Double flange Track roller, 8 each side
- Track shoe, 600 mm triple grouser

OPERATOR ENVIRONMENT:

- A/C with defroster
- Large high resolution LCD monitor
- Rear view mirrors (RH, LH, rear, sidewise)
- Seat belt, retractable
- Seat suspension
- Bolt-on top guard
- Cab front guard - Full height guard,

WORK EQUIPMENT:

- Boom
—6470 mm boom, heavy duty
- Arm
—2550 mm arm, heavy duty

OTHER EQUIPMENT:

- Large capacity Counterweight
- Electric horn
- Rear reflector
- Slip-resistant plates
- Fuel refill pump



OPTIONAL EQUIPMENT

HYDRAULIC SYSTEM:

- Service valve
- Rock breaker attachment piping kit

DGMS EQUIPMENT:

- Rear view camera
- Battery disconnect switch
- Audio visual Alarm
- Automatic fire suppression system

OPERATOR ENVIRONMENT:

- Cabin accessories
— Fan
- Manual fire extinguisher

WORK EQUIPMENT:

- Boom
—6000 mm boom assembly, heavy duty
- Arms
—2200 mm arm, heavy duty
—3185 mm arm, heavy duty
—2550 mm arm, heavy duty

ATTACHMENT:

- Hydraulic breaker
- Hydraulic quick coupler



Product improvement is a continuous process. Specifications given in this publication are therefore subject to change without notice.
Photographs depicted may be of optional equipment

www.komatsuindia.in

Printed on 02-2020

KOMATSU

Marketed & Serviced by:



L&T Construction & Mining Machinery

Larsen & Toubro Limited

1st Floor Lakshminarayan Complex, 10/1 Palace Road, Bengaluru- 560 052
Tel: 080 40401700 / 900
E-mail: ceb@larsentoubro.com www.lntcmb.com

Zonal Offices:

Delhi (011) 40819500
Nagpur (0712) 6606441/2260025
Jaipur (0141) 4385900

Kolkata (033) 44002433/22831442
Hyderabad (040) 47575064

Pune (020) 48544259
Chennai (044) 40706864

CIN: L99999MH1946PLC004768

Materials and specifications are subject to change without notice.
KOMATSU is a trademark of Komatsu Ltd. Japan.

KOMATSU®

PC350LC-8M0

PC
350LC

HORSEPOWER

Gross: 194 kW 260 HP / 1950 min⁻¹
Net: 187 kW 250 HP / 1950 min⁻¹

OPERATING WEIGHT

34020 – 35200 kg

BUCKET CAPACITY

1.4 – 2.30 m³



Photos may include optional equipment.

WALK-AROUND



PRODUCTIVITY, ECOLOGY & ECONOMY

- High Production and Low Fuel Consumption by Total Control of the Engine, Hydraulic and Electronic System
- Low Emission Engine and Low Operation Noise
- Large Drawbar Pull and Digging Force
- Two-mode Setting for Boom

COMFORT & SAFETY

- Large Comfortable Cabin
- Factory Fitted DGMS items (Optional)

ICT * & KOMTRAX

- Large High Resolution Liquid Crystal Display (LCD) Monitor
- Equipment Management Monitoring System
- KOMTRAX

* Information and Communication Technology

MAINTENANCE & RELIABILITY

- Easy Maintenance
- High Rigidity Work Equipment



	PC350LC-8M0
HORSEPOWER	Gross: 194 kW 260 HP / 1950 min ⁻¹ Net: 187 kW 250 HP / 1950 min ⁻¹
OPERATING WEIGHT	34020 – 35200 kg
BUCKET CAPACITY	1.4 – 2.3 m ³

Photos may include optional equipment.

PRODUCTIVITY, ECOLOGY & ECONOMY

Low Fuel Consumption

The newly-developed Komatsu SAA6D114E-3 engine enables NOx emissions to be significantly reduced with the accurate multi-stage fuel injection by the engine controller. It improves total engine durability using high-pressure fuel injection system developed specifically for construction machinery. This excavator significantly reduces hourly fuel consumption using the highly-efficient matching techniques of engine and hydraulic unit and also provides features that promote energy-saving operations such as the E mode and ECO gauge.

Fuel consumption

3% reduced

Vs. PC350LC-7
Based on typical work pattern collected via KOMTRAX.
Fuel consumption varies depending on job conditions.

Komatsu Technology

Komatsu develops and produces all major components, such as engines, electronics and hydraulic components, in house. With this "Komatsu Technology" and adding customer feedback, Komatsu is achieving great advancements in technology. To achieve both high levels of productivity and economical performance, Komatsu has developed the main components with a total control system. The result is a new generation of high performance and environment-friendly excavators.

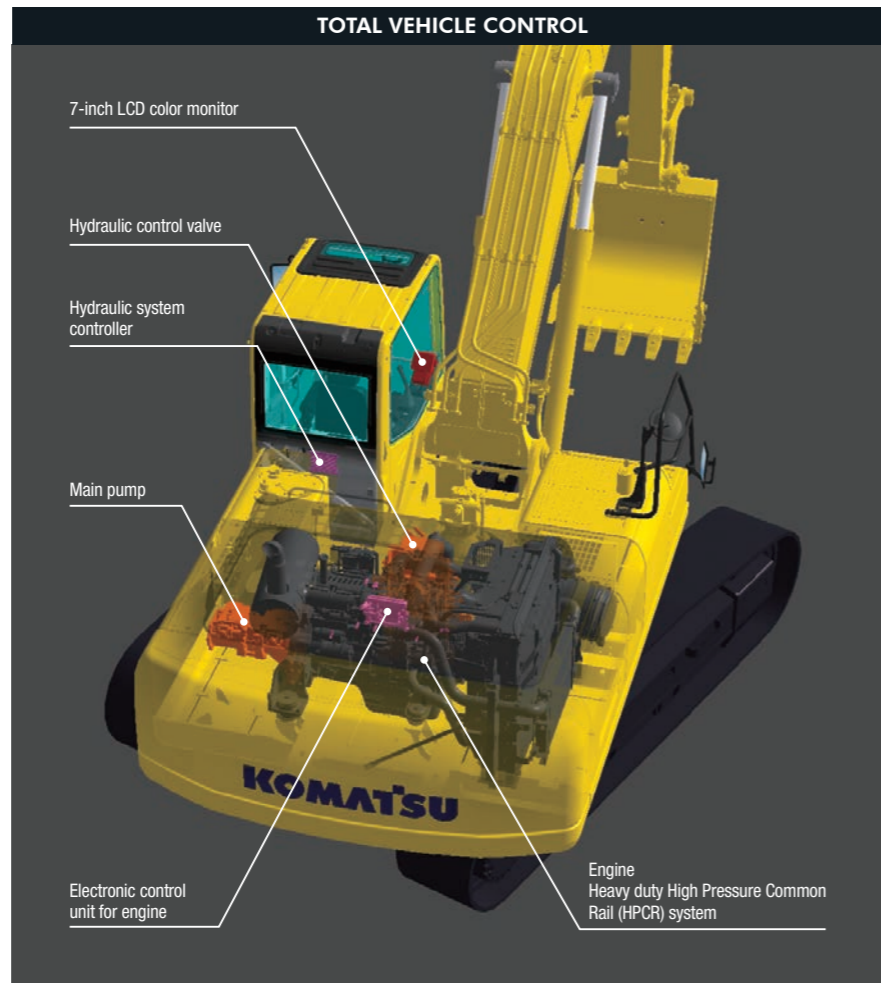

Low Emission Engine

Komatsu SAA6D114E-3 reduces NOx emission by 33% compared with the PC350LC-7. This engine is U.S. EPA Tier 3 and EU Stage 3A emission equivalent.



Low Operation Noise

Enables low noise operation using the low-noise engine and methods to cut noise at source.

Idling Caution

To prevent unnecessary fuel consumption, an idling caution is displayed on the monitor, if the engine idles for 5 minutes or more.



ECO Gauge that assists Energy-saving Operations

Equipped with the ECO gauge that can be recognized at a glance on the right of the multi-function color monitor for environment-friendly energy-saving operations. Allows focus on operation in the green range with reduced CO₂ emissions and efficient fuel consumption.



ECO gauge

Working Modes Selection

The PC350LC-8M0 excavator is equipped with six working modes (P, E, L, B, ATT/P and ATT/E mode). Each mode is designed to match engine speed and pump output to the application. This provides the flexibility to match equipment performance to the job at hand.



Working Mode	Application	Advantage
P	Power mode	<ul style="list-style-type: none"> Maximum production/power Fast cycle time
E	Economy mode	<ul style="list-style-type: none"> Good cycle time Better fuel economy
L	Lifting mode	<ul style="list-style-type: none"> Suitable attachment speed Lifting capacity is increased 7% by raising hydraulic pressure.
B	Breaker mode	<ul style="list-style-type: none"> Optimum engine rpm, hydraulic flow
ATT/P	Attachment Power mode	<ul style="list-style-type: none"> Optimum engine rpm, hydraulic flow, 2 way Power mode
ATT/E	Attachment Economy mode	<ul style="list-style-type: none"> Optimum engine rpm, hydraulic flow, 2 way Economy mode

Maximum Drawbar Pull

Maximum drawbar pull provides superb steering and slope climbing performance.



Maximum drawbar pull:
264 kN (26900 kgf)

High Digging Force

One-touch power max. switch when kept pressed, temporarily increases digging force for 8.5 seconds of operation.

Maximum arm crowd force (ISO 6015):
235 kN
(With Power Max.)

Maximum bucket digging force (ISO 6015):
259 kN
(With Power Max.)

(Measured with Power Max. function, 2220 mm arm and ISO 6015 rating.)



One-touch power max. switch

Smooth Loading Operation

Two return hoses improve hydraulic performance. In the arm out function, a portion of the oil is returned directly to the tank providing smooth operation.



Return hoses

Two-mode Setting for Boom

Smooth mode provides easy operation for gathering blasted rock or scraping down operation. When maximum digging force is needed, switch to Power mode (optional*) for more effective excavating.

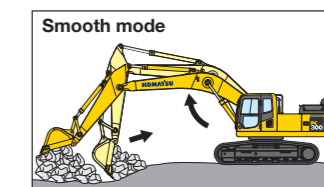

Smooth mode
Boom floats upward, reducing lifting of machine front. This facilitates gathering blasted rock and scraping down operations.

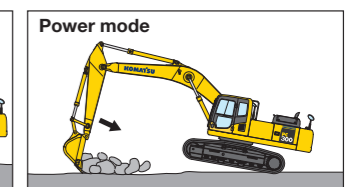

Power mode
Boom pushing force is increased, ditch digging and box digging operation on hard ground are improved.

*Not applicable for granite and marble application

COMFORT



Low Cab Noise

The cab is highly rigid and has excellent sound absorption ability. Thorough improvement of noise source reduction and use of low noise engine, hydraulic equipment, and air conditioner allows this machine to generate a low level of noise.

Wide Cab

Wide spacious cab includes seat with reclining backrest. The seat height and longitudinal inclination are easily adjusted using a pull-up lever. You can set the appropriate



operational posture of armrest together with the console. Reclining the seat further enables you to place it into the fully flat state with the headrest attached.

Pressurized Cab*

Standard air conditioner (A/C), air filter and higher internal air pressure prevent external dust from entering the cab.

Automatic Air Conditioner (A/C)

Enables you to easily and precisely set cab atmosphere with the instruments on the large LCD. The bi-level control function keeps the operator's head and feet cool and warm respectively. This improved air flow function keeps the inside of the cab comfortable throughout the year. Defroster function keeps front glass clear.

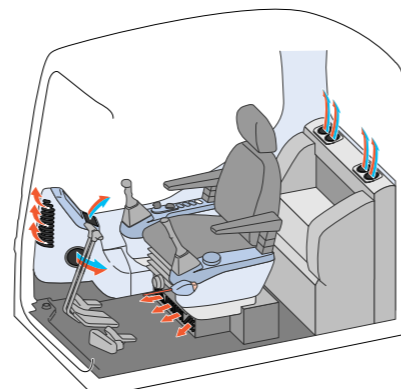

SAFETY

Slip-resistant Plates

Highly durable slip-resistant plates maintain superior traction performance for the long term.



Pump/Engine Room Partition

Pump/engine room partition prevents oil from spraying onto the engine if a hydraulic hose bursts.

Lock Lever

Locks the hydraulic pressure to prevent unintentional movement. Neutral start function allows machine to be started only in lock position.



Large Side-view, Rear and Sidewise Mirrors

Large right-side mirror and additional rear & right side mirrors allow the PC350LC-8M0 to meet the visibility requirements. (ISO 5006 : 2006)



Thermal and Fan Guards

Thermal and fan guards are placed around high-temperature parts of the engine and fan drive.



ICT & KOMTRAX

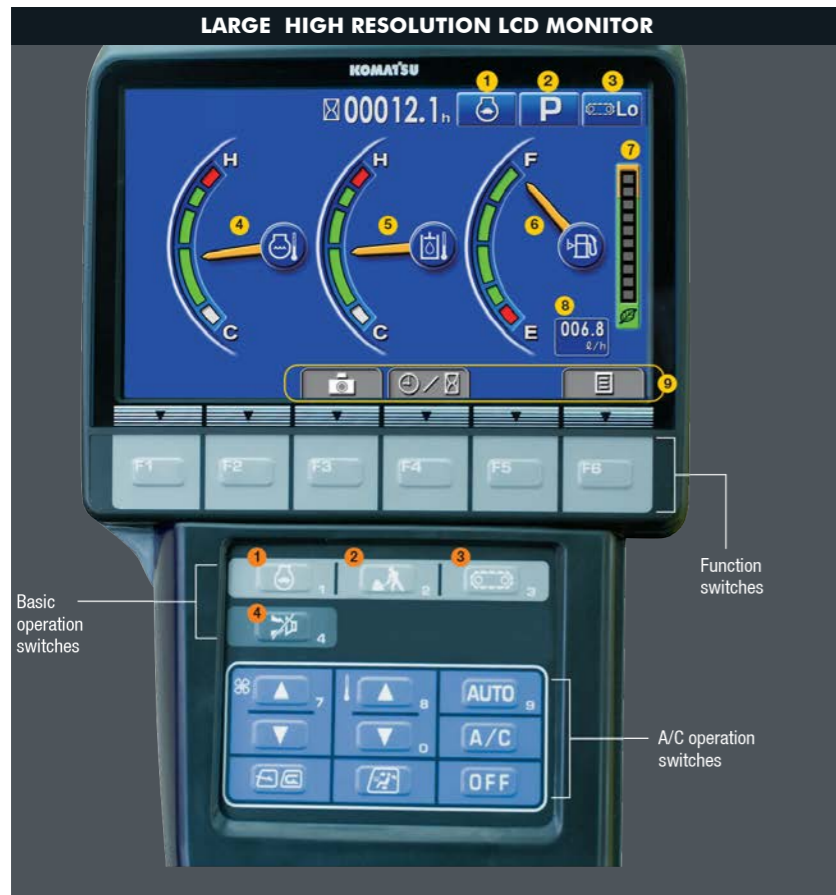

Large LCD Monitor

A large user-friendly high resolution LCD color monitor enables safe, accurate and smooth work. Visibility and resolution are further improved in 7-inch large LCD. Simple and easy to operate switches. Function keys facilitate multi-function operations. Displays data in various languages to support operators around the world.

Indicators

- 1 Auto-decelerator
- 2 Working mode
- 3 Travel speed
- 4 Engine water temperature gauge
- 5 Hydraulic oil temperature gauge
- 6 Fuel gauge
- 7 ECO gauge
- 8 Fuel consumption gauge
- 9 Function switches menu

Basic operation switches

- 1 Auto-decelerator
- 2 Working mode selector
- 3 Traveling selector
- 4 Buzzer cancel

Supports Efficiency Improvement

Main screen display advises for promoting energy-saving operations. The operator can use the ECO guidance menu to check the operation records, ECO guidance records, average fuel consumption logs, etc.



ECO guidance

ECO guidance menu

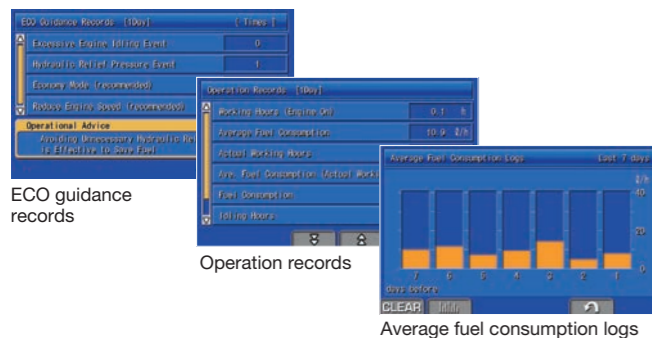

ECO guidance records

Operation records

Average fuel consumption logs

Equipment Management Monitoring System

Monitor function

Controller monitors engine oil level, coolant temperature, battery charge air clogging, etc. If the controller finds any abnormality, it is displayed on the LCD.

Maintenance function

The monitor informs replacement time of oil and filters on the LCD when the replacement interval is reached.

Trouble data memory function

Monitor stores abnormalities for effective troubleshooting.

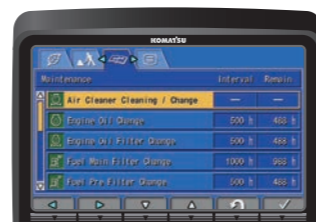

KOMTRAX

assists customer's equipment management and contributes to Fuel Cost Saving

Equipment Management Support

KOMTRAX terminal installed on your machine collects and sends information such as machine location, working record, machine conditions, etc. using wireless communication. You can review the KOMTRAX data remotely via the online application. KOMTRAX not only gives you information on your machine, but the convenience of managing your fleet on the web.

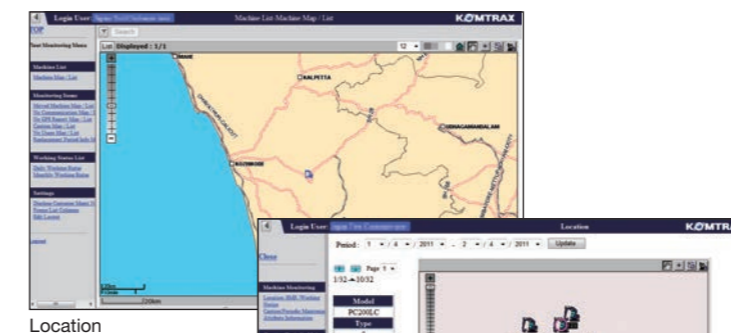

Location

Movement generated position

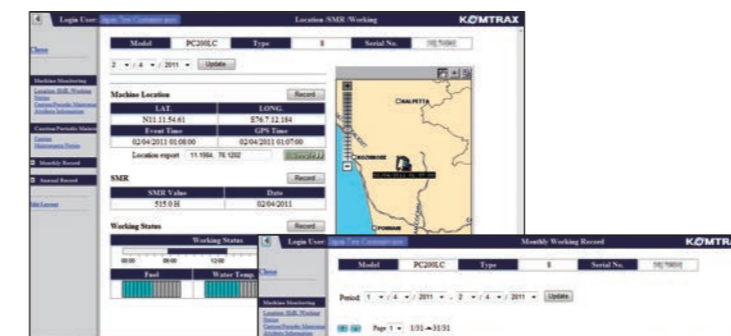

Operation map

Monthly status summary

Energy-saving Operation Report

KOMTRAX can provide various useful information which includes the energy-saving operation report created based on the operating information of your machine such as fuel consumption and idle time.

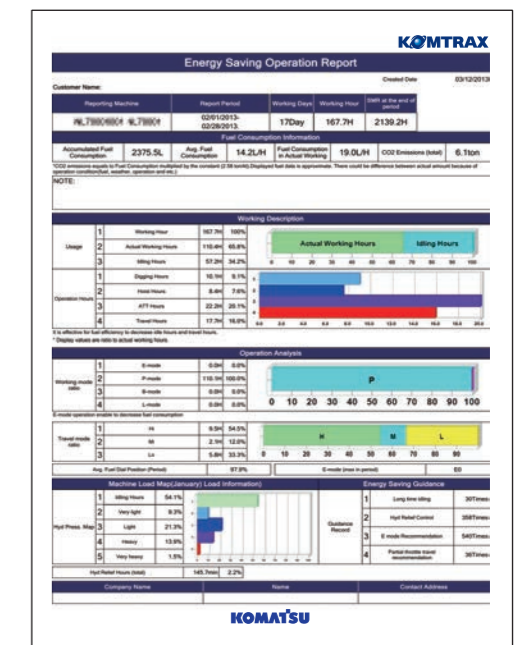

Image

MAINTENANCE

Side-by-side Cooling

Since radiator and oil cooler are arranged in parallel, it is easy to clean, remove and install them.



Equipped with Drain Valve as standard

Prevents clothes and the ground from becoming contaminated due to oil spillage and facilitates easy draining of engine oil during scheduled maintenance.

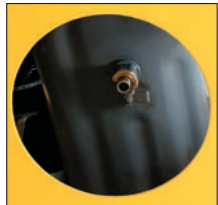

Easy Access to Engine Oil Filter and Fuel Drain Valve

Engine oil level gauge, and fuel filter are one side mounted to improve accessibility. Engine oil filter and fuel drain valve are remotely mounted to improve accessibility.



Engine oil filter



Fuel drain valve

Equipped with the Fuel Pre-filter (With Water Separator)

Removes water and contaminants in the fuel to ensure clean fuel flow to engine.



High-capacity Air Cleaner

High capacity air cleaner is comparable to that of larger machines. The larger air cleaner can extend air cleaner life during long-term operation and prevents early clogging and resultant power decrease. Reliability is improved by a new seal design.



Large Fuel Tank Capacity

Large capacity, rust prevention treated fuel tank extends operating hours before refueling.



RELIABILITY

High Rigid Work Equipment

Boom and arms are constructed of thick plates of high tensile strength steel. In addition, these structures are designed with large cross-sectional areas and generous use of castings.

The result is working attachments that exhibit long term durability and high resistance to bending and torsional stress.

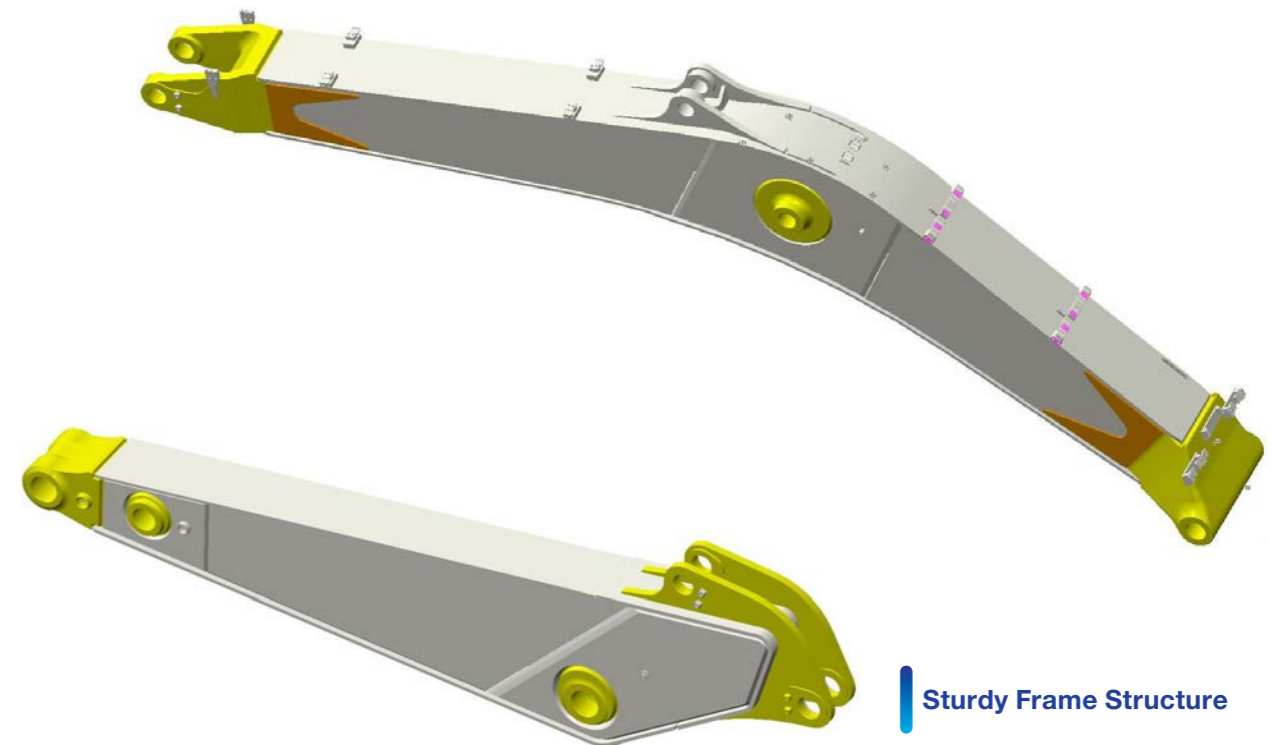

Grease Sealed Track

PC350LC-8M0 uses grease sealed tracks for extended undercarriage life.

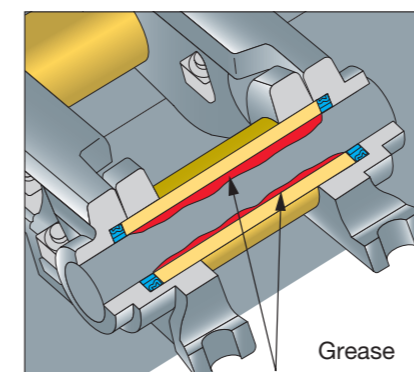

Grease

Track Link with Strut

PC350LC-8M0 uses track links with strut, providing superb durability.

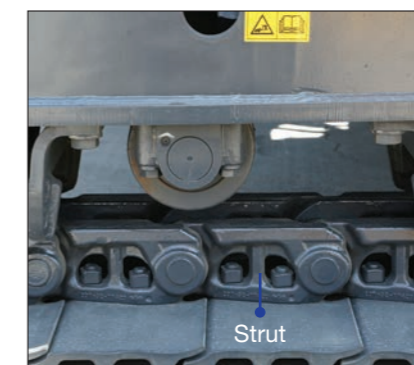

Strut

Sturdy Frame Structure

The revolving frame, center frame and undercarriage are designed by using the most advanced three-dimensional CAD and Finite Element Method (FEM) analysis technology.

Highly Reliable Electronic Devices

Exclusively designed electronic devices have passed severe testing.

- Controller
- Sensors
- Connectors
- Heat resistant wiring

Reliable Components

All major machine components, such as engine, hydraulic pumps, hydraulic motors and control valves are exclusively designed and manufactured by Komatsu ensuring reliable performance over long period of time.

KOMATSU BUCKET

HEAVY DUTY HYDRAULIC EXCAVATOR

Feature of [ME Bucket] (More suitable shape and Effectiveness Bucket)



High Productivity by Low-resistant Excavation

The new Ideal bucket profile produces lower resistance at inside & outside bucket and production will be greatly increased.

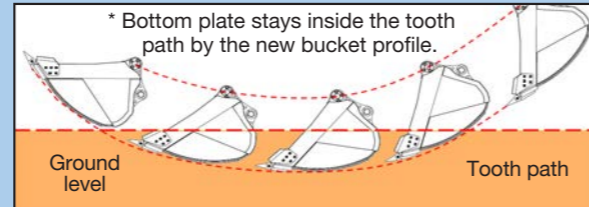

KOMATSU "ME" Bucket with Larger Width

"ME" More Efficient bucket options made available with additional wear plates and long service life

- Low resistant excavation
- High durability
- High productivity
- High fuel efficiency



Conventional

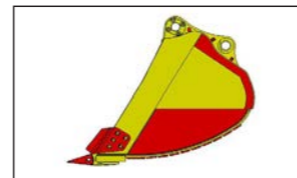

"ME" Bucket

Category and Feature

Category	Load / Wear / Soil (Application)	Image
More Efficient "ME"	Load High productivity by low-resistant excavation. Medium, but continuous load. Wear Material is not abrasive. Soil Loose soil, sand & clay	
Heavy Duty HD	Load Machine power is high during majority of the work. Medium, but continuous shock load. Wear Material is abrasive. Light scratch marks can be seen at the bucket. Soil Limestone, shot rock, compact mix of sand, gravel and clay.	
Extra Heavy Duty XHD	Load Machine power is high during most of the work, often at maximum. Dynamic shock loads are frequent and machine may shake. Wear Material is very abrasive. Large scratch marks are visible and, or deform metal. Works within heaps of rock with occasional un-shot rock and rock boulders. Soil Granite, basalt, quartz sand, compact and sticky clay.	

Bucket Line-up

Category	Working Condition	Bucket Capacity (Heaped) (Cu.m)	Width (mm)		Weight (kg)	Tooth Quantity	PC350LC-8M0 Boom+Arm(m)				
			Without side cutters	with side cutters			6.5+2.6	6+2.6	6.5+2.2	6+2.2	6.5+3.2
More Efficient (ME)	Iron Ore	1.90	1516	1616	1745	5	x	○	○	○	x
	Soft gravel & General construction	2.10	1493	1593	1990	5	x	□	□	□	x
Heavy duty	Irrigation & Soft soil work	2.30	1603	1703	2095	5	x	△	x	□	x
	Blue metal Quarry, Iron ore, Limestone	1.60	1549	1653	1740	5	x	○	○	○	x
Extra Heavy duty (XHD)	Granite & Marble Block	1.40	1412	1516	1645	5	○	x	x	x	○

○: Material upto 1.8 ton/m³ □: Material upto 1.5 ton/m³ △: Material upto 1.2 ton/m³ ×: Not usable

Heavy Duty Hydraulic Excavator - Specifications

Equips PC350LC-8M0 for Granite and Marble segments.

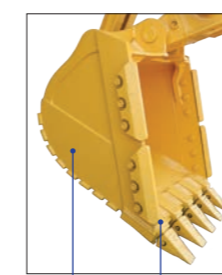
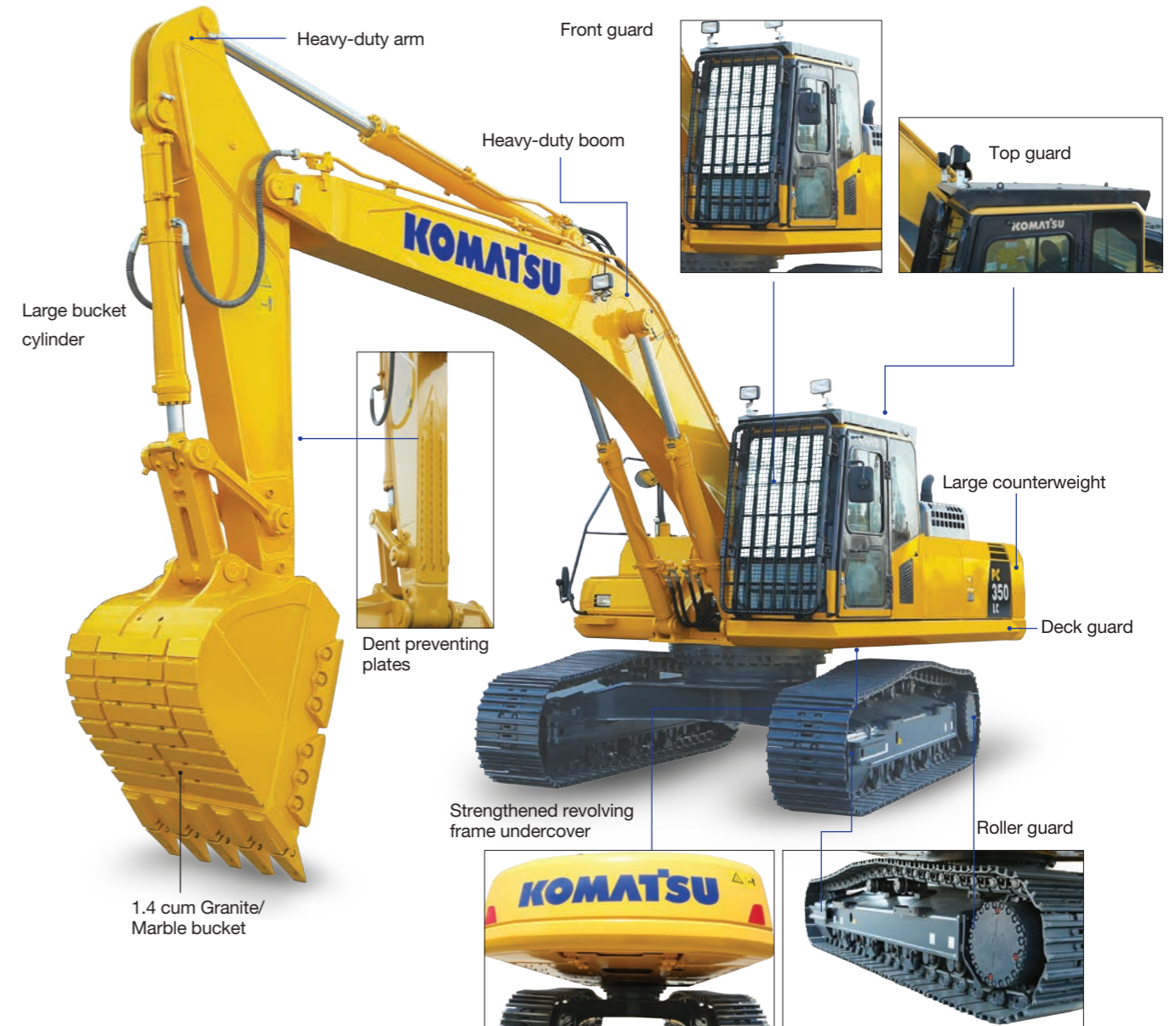

Side shrouds
Side reinforcement plates

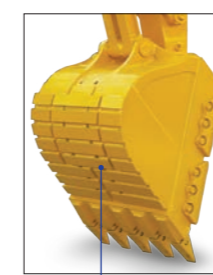

Bottom wear plates



Long life bucket teeth

Overall track link width increase by **25%** vs track link width of PC300LC-7

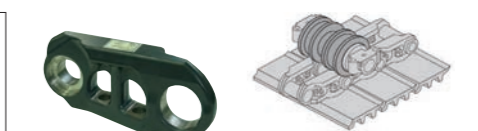

Double-flange track roller
Double-flange roller guides track link correctly and extends life of undercarriage.

Number of double-flange track rollers PC350LC-8M0..... 8 each side

ATTACHMENT

Special Purpose Bucket

Feature and Specifications

Type	Machine Spec.	Feature	Width/Weight	Image
Block Handling Bucket	Block handling bucket suitable for 6470 mm Boom, 2550 mm and 3185 mm arm.	Easy to handle Granite & Marble Blocks	1450 mm 1597 kg	



ATTACHMENT

Komatsu Genuine Attachment Tool

A wide range of Komatsu-genuine attachment tools for hydraulic excavators are provided to suit customers' specific applications.

Hydraulic breaker

The hydraulic breaker is an attachment tool used for breaking rock beds and paved surfaces, demolishing concrete structures, etc. The large gas chamber, ideal gas ratio and long-stroke piston deliver a powerful impact force. Since the breaker unit does not require an accumulator, the number of parts has been reduced, resulting in lower maintenance costs.

Komatsu breaker delivers high impact force with every blow thus, ideal choice for primary & secondary breaking.

Model type		JTHB355-5
Working weight	kg	2880
Oil flow	l/min	180 - 230
Operating pressure	MPa	13 - 18
Impact rate	bpm	350 - 450
Chisel diameter	mm	ø 155

- Anti-Blank Blow System
- Accumulator FREE design
- High Impact Energy
- High Reliability & Durability
- Low Operating Cost



Hydraulic Quick Coupler

Hydraulic Quick Coupler is used to facilitate frequent changes between attachments such as bucket, breaker etc., thus, saves time and reduces operator fatigue. The Twin Lock series Hydraulic Quick Coupler is completely automatic and with Automatic Blocking System makes the operation easy and safe.

- Fully Automatic (Hydraulic coupling)
- Twin Lock Mechanism
- Automatic Blocking System (ABS)
- Blocking Bar
- Lifting Eye
- Casting Manufacturing



Photos may include optional equipment.

KOMATSU TOTAL SUPPORT



Komatsu Total Support

To keep your machine available and minimize operation costs, L&T CMB (Komatsu Distributor) provides total equipment support before and after procuring the machine.

Fleet recommendation

L&T CMB will study the customer jobsite and provide the most optimum fleet recommendation with detailed information to meet your application needs when you are considering to buy new machines or to replace the existing ones.

Technical support

L&T CMB offers effective services for maintenance and support of Komatsu machine.

- Preventive Maintenance (PM) clinic
- Oil & Wear analysis program
- Undercarriage inspection service
- Hose inspection

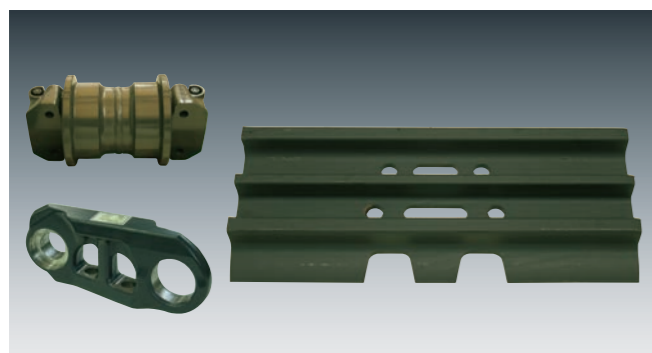

Product support

Komatsu machines are supported by Larsen & Toubro's strong nationwide network, parts outlets and service centers.

Parts availability

L&T CMB is available for regular and emergency requirements of the customers for supply of genuine and quality guaranteed Komatsu parts.

Repair & maintenance service

L&T CMB offers quality repair service and periodical maintenance to the customers, while utilizing and promoting Komatsu programs.

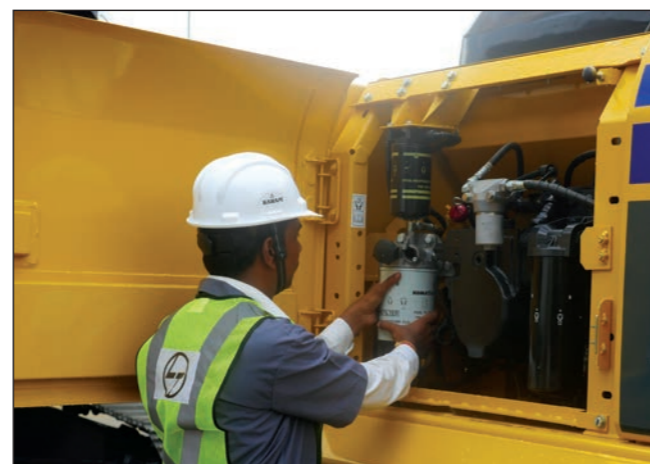

SPECIFICATIONS



ENGINE

Model Komatsu SAA6D114E-3
 Type Water-cooled, 4-cycle, direct injection
 Aspiration Turbocharged, aftercooled
 Number of cylinders 6
 Bore 114 mm
 Stroke 135 mm
 Piston displacement 8.27 L
 Horsepower:
 SAE J1995 Gross 194 kW 260 HP
 ISO 9249 / SAE J1349 Net 187 kW 250 HP
 Rated rpm 1950 min⁻¹
 Fan drive method for radiator cooling Mechanical Governor
 Governor All-speed control, electronic
 U.S. EPA Tier 3 and EU Stage 3A emissions equivalent.



HYDRAULICS

Type HydrauMind (Hydraulic Mechanical Intelligence New Design) system, closed-center system with load sensing valves and pressure compensated valves
 Number of selectable working modes 6
 Main pump:
 Type Two variable displacement piston type
 Pumps for Boom, arm, bucket, swing, and travel circuits
 Maximum flow 535 L/min
 Supply for control circuit Self-reducing valve
 Hydraulic motors:
 Travel 2 x axial piston motor with parking brake
 Swing 1 x axial piston motor with swing holding brake
 Relief valve setting:
 Implement circuits 37.3 MPa 380 kg/cm²
 Travel circuit 37.3 MPa 380 kg/cm²
 Swing circuit 27.9 MPa 285 kg/cm²
 Pilot circuit 3.2 MPa 33 kg/cm²
 Hydraulic cylinders:
 (Number of cylinders – bore x stroke x rod diameter)
 Boom 2–140 mm x 1480 mm x 100 mm
 Arm 1–160 mm x 1825 mm x 110 mm
 Bucket for 3.19 m and
 2.55 m arm 1–140 mm x 1285 mm x 100 mm
 for 2.22 m arm 1–150 mm x 1285 mm x 110 mm



DRIVES AND BRAKES

Steering control Two levers with pedals
 Drive method Hydrostatic
 Maximum drawbar pull 264 kN 26900 kg
 Gradeability 70%, 35°
 Maximum travel speed: High 5.5 km/h (Auto-shift) Mid 4.5 km/h (Auto-shift) Low 3.2 km/h
 Service brake Hydraulic lock
 Parking brake Mechanical disc brake



SWING SYSTEM

Drive method Hydrostatic
 Swing reduction Planetary gear
 Swing circle lubrication Grease-bathed
 Service brake Hydraulic lock
 Holding brake/Swing lock Mechanical disc brake
 Swing speed 9.5 min⁻¹



UNDERCARRIAGE

Center frame X-frame
 Track frame Box-section
 Seal of track Sealed track
 Track adjuster Hydraulic
 Number of shoes (Each side) 48
 Number of carrier rollers 2 each side
 Number of track rollers (Each side) 8



COOLANT AND LUBRICANT CAPACITY (REFILLING)

Fuel tank 605 L
 Coolant 31 L
 Engine 37 L
 Final drive (Each side) 9 L
 Swing drive 16 L
 Hydraulic tank 188 L



OPERATING WEIGHT (APPROXIMATE)

Operating weight including 600mm Shoes with rated capacity of lubricants, coolant, full fuel tank, operator, and standard equipment.

Configuration	PC350LC-8M0	
	Operating Weight	Ground Pressure
6470 mm One-piece Boom 2550 mm Arm SAEJ296 heaped 1.40 M ³ Bucket	34350 kg	63.9 kPa 0.65 kg/cm ²
6470 mm One-piece Boom 3200 mm Arm SAEJ296 heaped 1.40 M ³ Bucket	34560 kg	65.7 kPa 0.67 kg/cm ²

Configuration	PC350LC-8M0	
	Operating Weight	Ground Pressure
6000 mm One-piece Boom 2200 mm Arm SAEJ296 heaped 2.30 M ³ Bucket	34650 kg	65.7 kPa 0.67 kg/cm ²
6000 mm One-piece Boom 2550 mm Arm SAEJ296 heaped 2.30 M ³ Bucket	34770 kg	65.7 kPa 0.67 kg/cm ²



LIFTING CAPACITY WITH LIFTING MODE

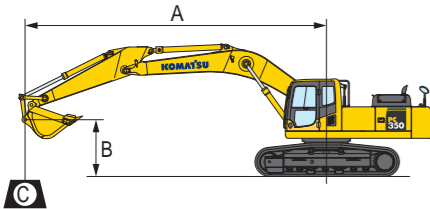

PC350LC-8M0

- A: Reach from swing center
- B: Bucket hook height
- C: Lifting capacity
- Cf: Rating over front
- Cs: Rating over side
- ⊕: Rating at maximum reach

PC350LC-8M0 Boom: 6470 mm Arm: 2550 mm Bucket: 1.4 CUM													
B	A	⊕ MAX REACH		9.0m (29')		7.5 m (24')		6.0 m (19')		4.5 m (14')		3.0 m (9')	
		RADIUS	Cf	Cs	Cf	Cs	Cf	Cs	Cf	Cs	Cf	Cs	Cf
7.5 m (24')	7.15 m (23.5')	*7200 (15800)	6400 (14100)										
6.0 m (19')	8.10 m (26.6')	*7050 (15600)	4950 (10900)			*7300 (16100)	5800 (12800)						
4.5 m (14')	8.69 m (28.2')	7000 (15400)	4150 (9200)			*7800 (17100)	5600 (12300)	*9400 (20700)	8300 (18300)	*12600 (27700)	*12600 (27700)		
3.0 m (9')	8.99 m (29.5')	6400 (14200)	3750 (8300)	6400 (14100)	3750 (8300)	*8500 (18700)	5300 (11700)	*10750 (23700)	7750 (17100)	*14900 (32900)	12300 (27100)		
1.5 m (4')	9.03 m (29.6')	6250 (13800)	3650 (8000)	6250 (13800)	3650 (8000)	8550 (18900)	5050 (11100)	*11750 (25900)	7300 (16100)				
0.0 m (0')	8.81 m (28.9')	6400 (14200)	3700 (8200)	6150 (13600)	3550 (7800)	8350 (18400)	4850 (10700)	*12000 (26500)	7000 (15400)	*14000 (30900)	11050 (24400)		
-1.5 m (-4')	8.32 m (27.3')	7000 (15500)	4050 (9000)			8250 (18200)	4800 (10600)	*11700 (25700)	6900 (15200)	*15550 (34300)	11100 (24500)		
-3.0 m (-9')	7.49 m (24.6')	*7450 (16400)	4900 (10800)			*7600 (16700)	4900 (10800)	*10450 (23000)	6950 (15400)	*13650 (30100)	11300 (24900)	*16550 (36500)	*16550 (36500)
-4.5 m (-14')	6.20 m (20.3')	*6850 (15100)	*6850 (15100)					*7750 (17000)	7200 (15900)	*10450 (23000)	*10450 (23000)	*12500 (27500)	*12500 (27500)
-6.0 m (-19')													

*LOAD IS LIMITED BY HYDRAULIC CAPACITY RATHER THAN TIPPING. RATINGS ARE BASED ON SAE STANDARD No. J1097
RATED LOADS DO NOT EXCEED 87% OF HYDRAULIC LIFT CAPACITY 75% OF TIPPING LOAD.

PC350LC-8M0 Boom: 6000 mm Arm: 2200 mm Bucket: 2.3 CUM													
B	A	⊕ MAX REACH		9.0m (29')		7.5 m (24')		6.0 m (19')		4.5 m (14')		3.0 m (9')	
		RADIUS	Cf	Cs	Cf	Cs	Cf	Cs	Cf	Cs	Cf	Cs	Cf
7.5 m (24')	5.96 m (19.5')	*8550 (18900)	*8550 (18900)					*8200 (18000)	*8200 (18000)				
6.0 m (19')	7.07 m (23.2')	*8100 (17900)	6150 (13600)					*8550 (18900)	*8500 (18700)				
4.5 m (14')	7.74 m (25.4')	*8000 (17700)	5000 (1100)			*8050 (17700)	5300 (11700)	*9550 (21000)	8050 (17700)	*12650 (27900)	*12650 (27900)		
3.0 m (9')	8.08 m (26.5')	7600 (16800)	4450 (9800)			*8550 (18800)	5050 (11200)	*10800 (23900)	7650 (16800)	*14900 (32900)	12350 (27200)		
1.5 m (4')	8.12 m (26.6')	7350 (16200)	4250 (9400)			8350 (18500)	4850 (10700)	*11700 (25800)	7200 (15900)	*16650 (36700)	11450 (25300)		
0.0 m (0')	7.88 m (25.8')	7650 (16900)	4400 (9700)			8300 (18300)	4800 (10500)	*11900 (26300)	6950 (15400)	*16550 (36500)	11150 (24600)		
-1.5 m (-4')	7.32 m (24.0')	*8500 (18700)	4950 (1100)			*8050 (17800)	4750 (10400)	*11300 (24900)	6900 (15200)	*15200 (33500)	11100 (24700)		
-3.0 m (-9')	6.36 m (20.9')	*8350 (18400)	6400 (14100)					*9400 (20700)	7050 (15500)	*12700 (28000)	11400 (25200)	*15250 (33600)	*15250 (33600)
-4.5 m (-14')	4.76 m (15.6')	*6950 (15300)	*6950 (15300)							*8100 (17800)	*8100 (17800)		
-6.0 m (-19')													

*LOAD IS LIMITED BY HYDRAULIC CAPACITY RATHER THAN TIPPING. RATINGS ARE BASED ON SAE STANDARD No. J1097
RATED LOADS DO NOT EXCEED 87% OF HYDRAULIC LIFT CAPACITY 75% OF TIPPING LOAD.

PC350LC-8M0 Boom: 6470 mm Arm: 3185 mm Bucket: 1.4 CUM													
B	A	⊕ MAX REACH		9.0m (29')		7.5 m (24')		6.0 m (19')		4.5 m (14')		3.0 m (9')	
		RADIUS	Cf	Cs	Cf	Cs	Cf	Cs	Cf	Cs	Cf	Cs	Cf
7.5 m (24')	7.84 m (25.7')	*4900 (10800)	*4900 (10800)			*6500 (14300)	6000 (13300)						
6.0 m (19')	8.71 m (28.6')	*4850 (10600)	4300 (9500)			*6650 (14600)	5950 (13100)						
4.5 m (14')	9.26 m (30.4')	*4950 (10900)	3700 (8100)	*6400 (14200)	3950 (8700)	*7200 (15900)	5700 (12600)	*8600 (19000)	8500 (18800)				
3.0 m (9')	9.54 m (31.3')	*5300 (11700)	3350 (7400)	6450 (14200)	3800 (8400)	*8000 (17600)	5400 (11900)	*10050 (22200)	7950 (17600)	*14450 (31800)	12800 (28200)		
1.5 m (4')	9.58 m (31.4')	5650 (12400)	3200 (7100)	6300 (13800)	3600 (8000)	*8600 (19000)	5100 (11200)	*11300 (24900)	7400 (16400)	*15950 (35200)	11700 (25800)		
0.0 m (0')	9.37 m (30.8')	5750 (12700)	3250 (7200)	6150 (13500)	3500 (7700)	8350 (18500)	4850 (10700)	*11850 (26200)	7050 (15500)	*16700 (36900)	11150 (24500)		
-1.5 m (-4')	8.91 m (29.2')	6200 (13700)	3550 (7800)	6100 (13400)	3450 (7600)	8250 (18200)	4750 (10500)	*11800 (26000)	6850 (15100)	*16200 (35700)	11000 (24200)	*9000 (19800)	*9000 (19800)
-3.0 m (-9')	8.14 m (26.7')	*7000 (15500)	4150 (9100)			*8250 (18100)	4750 (10500)	*11000 (24200)	6850 (15100)	*14700 (32400)	11100 (24500)	*16150 (35600)	*16150 (35600)
-4.5 m (-14')	6.98 m (22.9')	*6850 (15100)	*5550 (12100)					*9050 (19900)	7050 (15500)	*12050 (26600)	11300 (24900)	*15700 (34600)	*15700 (34600)
-6.0 m (-19')	5.12 m (16.8')	*5550 (12300)	*5550 (12300)							*7400 (16300)	*7400 (16300)		

*LOAD IS LIMITED BY HYDRAULIC CAPACITY RATHER THAN TIPPING. RATINGS ARE BASED ON SAE STANDARD No. J1097
RATED LOADS DO NOT EXCEED 87% OF HYDRAULIC LIFT CAPACITY 75% OF TIPPING LOAD.

PC350LC-8M0 Boom: 6000 mm Arm: 2550 mm Bucket: 2.3 CUM													
B	A	⊕ MAX REACH		9.0m (29')		7.5 m (24')		6.0 m (19')		4.5 m (14')		3.0 m (9')	
		RADIUS	Cf	Cs	Cf	Cs	Cf	Cs	Cf	Cs	Cf	Cs	Cf
7.5 m (24')	6.63 m (21.7')	*6700 (14800)	*6700 (14800)										
6.0 m (19')	7.64 m (25.1')	*6550 (14400)	5300 (11700)			*7400 (16400)	5500 (12100)						
4.5 m (14')	8.27 m (27.1')	*6700 (14800)	4450 (9800)			*7800 (17200)	5350 (11800)	*9250 (20400)	8100 (17800)	*12100 (26700)	*12100 (26700)		
3.0 m (9')	8.58 m (28.1')	6850 (15100)	4000 (8800)			8400 (18500)	5100 (11200)	*10600 (23400)	7750 (17100)	*15400 (34000)	12600 (27700)		
1.5 m (4')	8.62 m (28.3')	6650 (14700)	3850 (8400)			8350 (18400)	4850 (10700)	*11650 (25700)	7300 (16100)	*16450 (36300)	11650 (25700)		
0.0 m (0')	8.39 m (27.5')	6900 (15200)	3950 (8700)			8300 (18300)	4800 (10600)	*12000 (26400)	7000 (15500)	*16850 (37100)	11250 (24800)		
-1.5 m (-4')	7.87 m (25.8')	7650 (16800)	4400 (9700)			8250 (18200)	4750 (10500)	*11600 (25600)	6900 (15300)	*15850 (34900)	11200 (24700)	*15250 (33600)	*15250 (33600)
-3.0 m (-9')	6.99 m (22.9')	*7700 (17000)	5450 (12100)					*10100 (22200)	7000 (15400)	*13650 (30100)	11400 (25100)	*17450 (38500)	*17450 (38500)
-4.5 m (-14')	5.58 m (18.3')	*6800 (15000)	*6800 (15000)							*9600 (21200)	*9600 (21200)	*11950 (26400)	*11950 (26400)
-6.0 m (-19')													

*LOAD IS LIMITED BY HYDRAULIC CAPACITY RATHER THAN TIPPING. RATINGS ARE BASED ON SAE STANDARD No. J1097
RATED LOADS DO NOT EXCEED 87% OF HYDRAULIC LIFT CAPACITY 75% OF TIPPING LOAD.